

## 30V N-Ch Power MOSFET

### Feature

- ◇ High Speed Power Switching, Logic Level
- ◇ Enhanced Avalanche Ruggedness
- ◇ 100% UIS Tested, 100% Rg Tested
- ◇ Lead Free, Halogen Free

$V_{DS}$		30	V
$R_{DS(on),typ}$	$V_{GS}=10V$	3.2	$m\Omega$
$I_D$ (Silicon Limited)		32	A

### Application

- ◇ Hard Switching and High Speed Circuit
- ◇ DC/DC in Telecoms and Industrial

DFN3x3

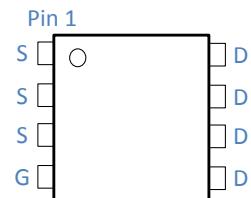
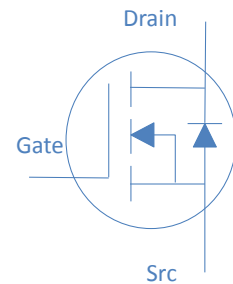
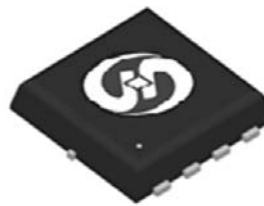

Part Number	Package	Marking
HTM040N03	DFN3*3	TM040N03

### Absolute Maximum Ratings at $T_j=25^\circ\text{C}$ (unless otherwise specified)

Parameter	Symbol	Conditions	Value	Unit
Continuous Drain Current (Silicon Limited)	$I_D$	$T_C=25^\circ\text{C}$	32	A
		$T_C=100^\circ\text{C}$	22	
Drain to Source Voltage	$V_{DS}$	-	30	V
Gate to Source Voltage	$V_{GS}$	-	$\pm 20$	V
Pulsed Drain Current	$I_{DM}$	-	128	A
Avalanche Energy, Single Pulse	$E_{AS}$	$L=0.1\text{mH}, T_C=25^\circ\text{C}$	51.2	mJ
Power Dissipation	$P_D$	$T_C=25^\circ\text{C}$	21	W
Operating and Storage Temperature	$T_J, T_{stg}$	-	-55 to 150	$^\circ\text{C}$

### Absolute Maximum Ratings

Parameter	Symbol	Max	Unit
Thermal Resistance Junction-Ambient	$R_{\theta JA}$	50	$^\circ\text{C/W}$
Thermal Resistance Junction-Case	$R_{\theta JC}$	6	$^\circ\text{C/W}$

**Electrical Characteristics at  $T_J=25^{\circ}\text{C}$  (unless otherwise specified)**
**Static Characteristics**

Parameter	Symbol	Conditions	Value			Unit
			min	typ	max	
Drain to Source Breakdown Voltage	$V_{(BR)DSS}$	$V_{GS}=0V, I_D=250\mu A$	30	-	-	V
Gate Threshold Voltage	$V_{GS(th)}$	$V_{GS}=V_{DS}, I_D=250\mu A$	1	1.5	3	
Zero Gate Voltage Drain Current	$I_{DSS}$	$V_{GS}=0V, V_{DS}=24V, T_J=25^{\circ}\text{C}$	-	-	1	$\mu A$
		$V_{GS}=0V, V_{DS}=20V, T_J=125^{\circ}\text{C}$	-	-	25	
Gate to Source Leakage Current	$I_{GSS}$	$V_{GS}=\pm 20V, V_{DS}=0V$	-	-	$\pm 100$	nA
Drain to Source on Resistance	$R_{DS(on)}$	$V_{GS}=10V, I_D=16A$	-	3.2	4	m $\Omega$
		$V_{GS}=4.5V, I_D=12A$	-	4.9	6.6	
Transconductance	$g_{fs}$	$V_{DS}=5V, I_D=16A$	-	26	-	S
Gate Resistance	$R_G$	$V_{GS}=15mV, V_{DS}=0V, f=1MHz$	-	2.4	-	$\Omega$

**Dynamic Characteristics**

Input Capacitance	$C_{iss}$	$V_{GS}=0V, V_{DS}=15V, f=1MHz$	-	2806	-	pF
Output Capacitance	$C_{oss}$		-	378	-	
Reverse Transfer Capacitance	$C_{rss}$		-	202	-	
Total Gate Charge	$Q_g(10V)$	$V_{DD}=15V, I_D=16A, V_{GS}=10V$	-	42	-	nC
	$Q_g(4.5V)$		-	21	-	
Gate to Source Charge	$Q_{gs}$		-	4.7	-	
Gate to Drain (Miller) Charge	$Q_{gd}$		-	9.3	-	
Turn on Delay Time	$t_{d(on)}$	$V_{DD}=15V, I_D=1A, V_{GS}=10V,$ $R_G=2.7\Omega,$	-	18	-	ns
Rise time	$t_r$		-	15	-	
Turn off Delay Time	$t_{d(off)}$		-	55	-	
Fall Time	$t_f$		-	20	-	

**Reverse Diode Characteristics**

Diode Forward Voltage	$V_{SD}$	$V_{GS}=0V, I_F=32A$	-		1.3	V
Reverse Recovery Time	$t_{rr}$	$I_F=32A, di_F/dt=100A/\mu s$	-	30	-	ns
Reverse Recovery Charge	$Q_{rr}$		-	10	-	nC

Fig 1. Typical Output Characteristics

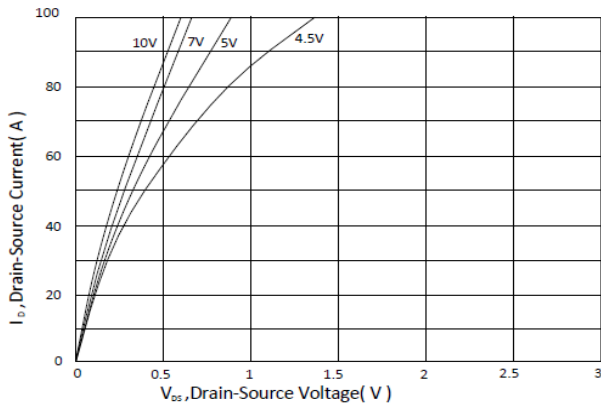

Figure 2. On-Resistance vs. Gate-Source Voltage

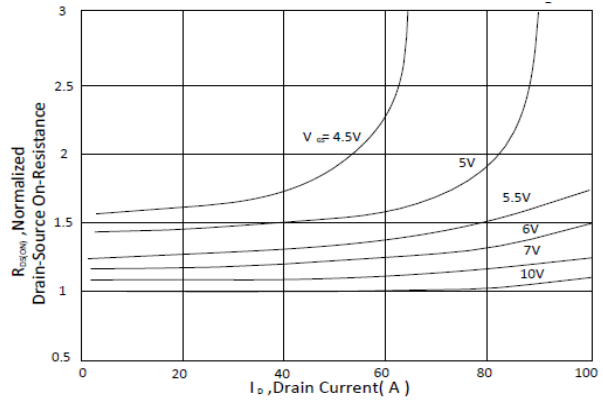

Figure 3. On-Resistance vs. Drain Current and Gate Voltage

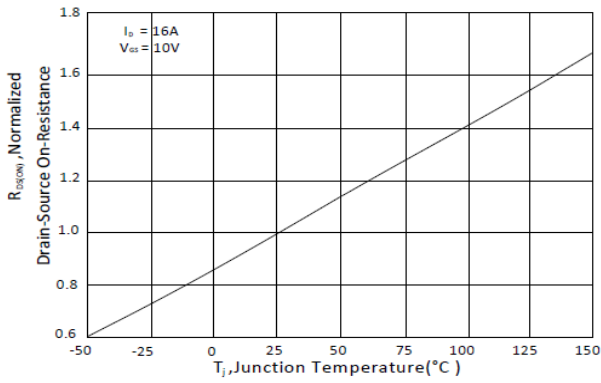

Figure 4. Normalized On-Resistance vs. Junction Temperature

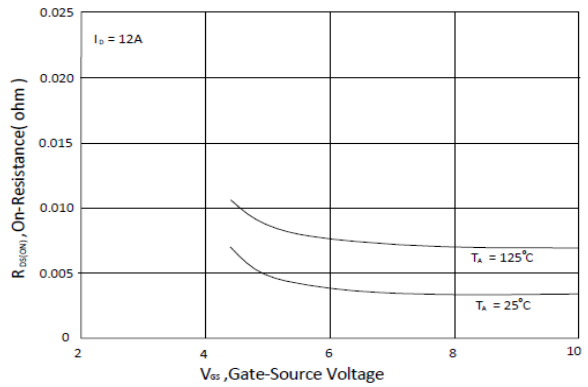

Figure 5. Typical Transfer Characteristics

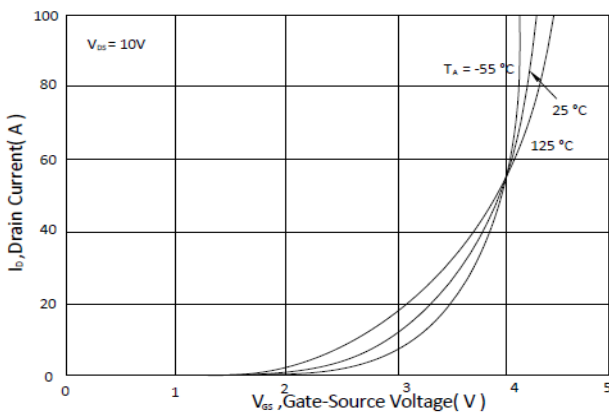

Figure 6. Typical Source-Drain Diode Forward Voltage

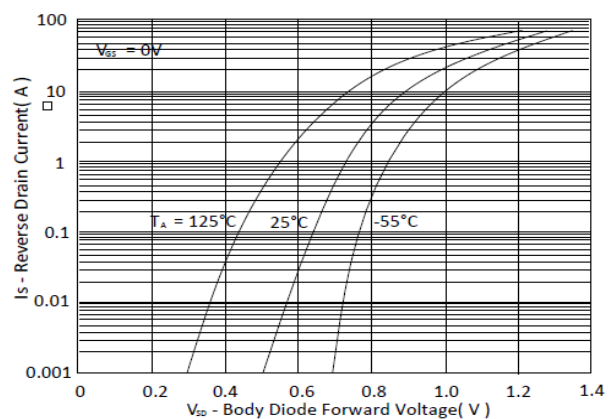

Figure 7. Typical Gate-Charge vs. Gate-to-Source Voltage

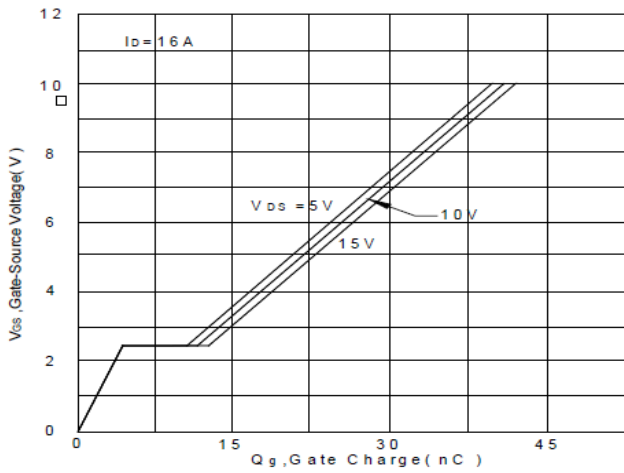

Figure 8. Typical Capacitance vs. Drain-to-Source Voltage

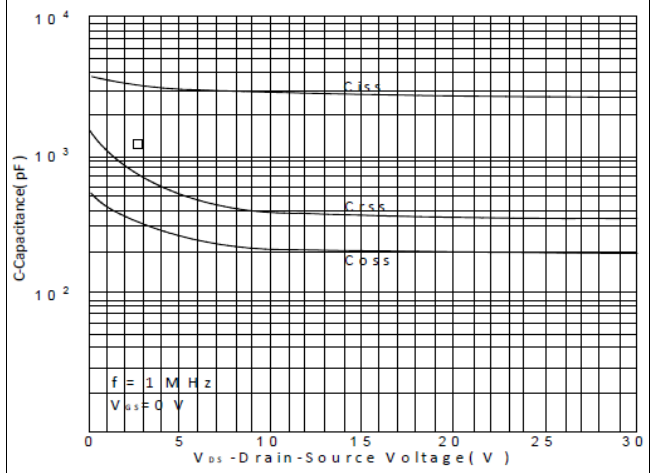

Figure 9. Maximum Safe Operating Area

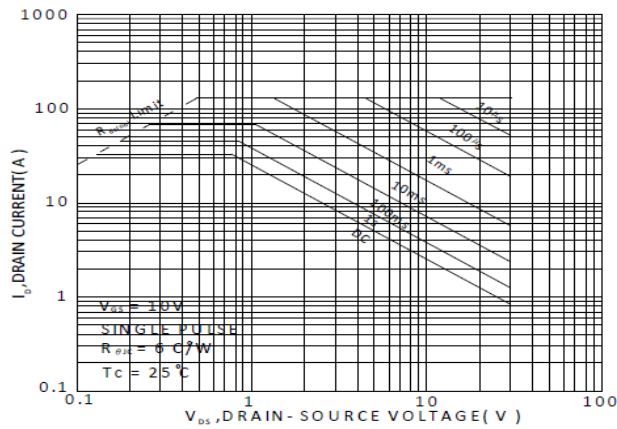

Figure 10. Single Pulse Maximum Power Dissipation

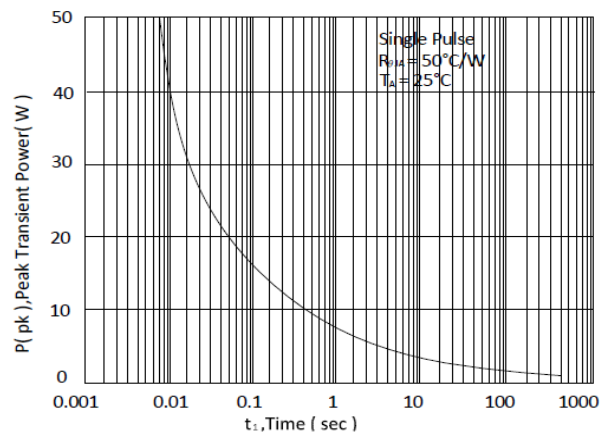
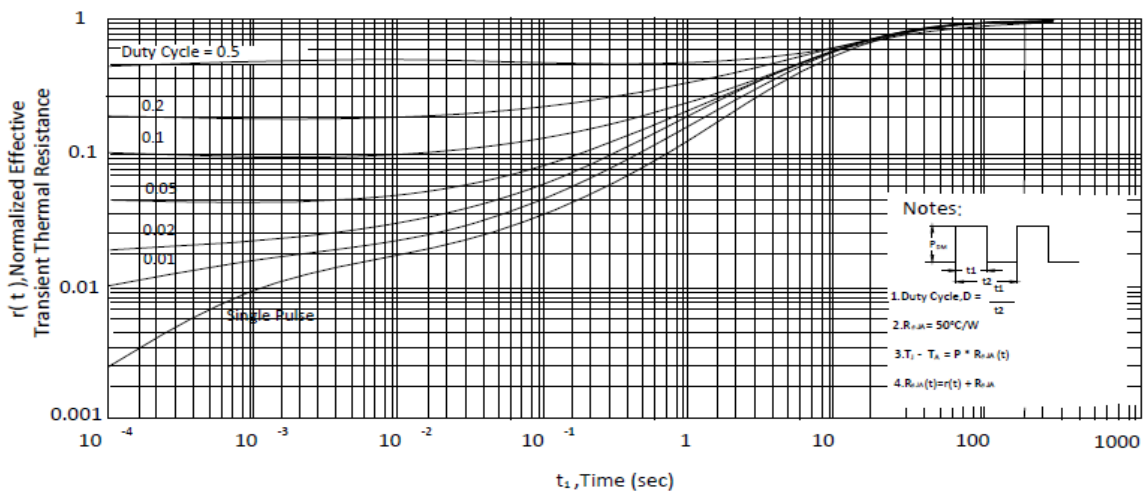
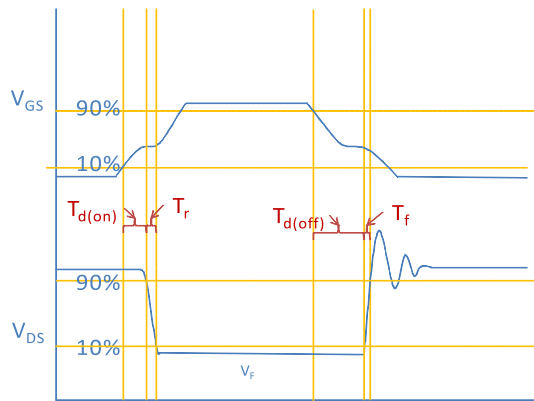

Figure 11. Normalized Maximum Transient Thermal Impedance, Junction-to-Ambient



Inductive switching Test



Gate Charge Test

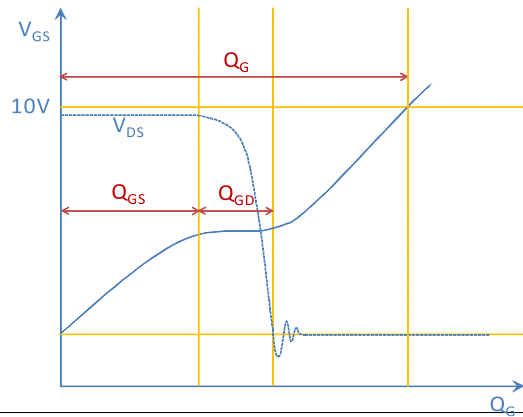
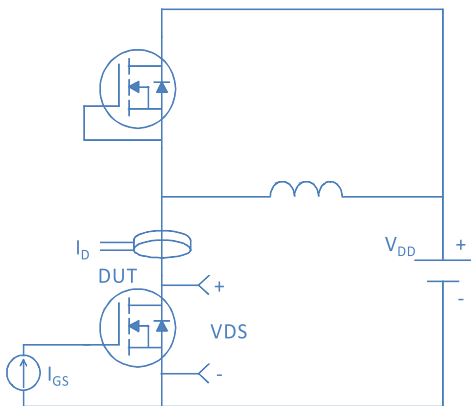

Uclamped Inductive Switching (UIS) Test

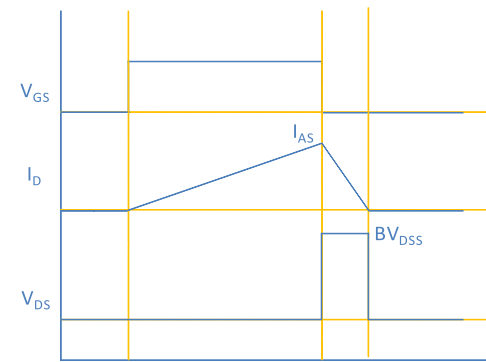

Diode Recovery Test

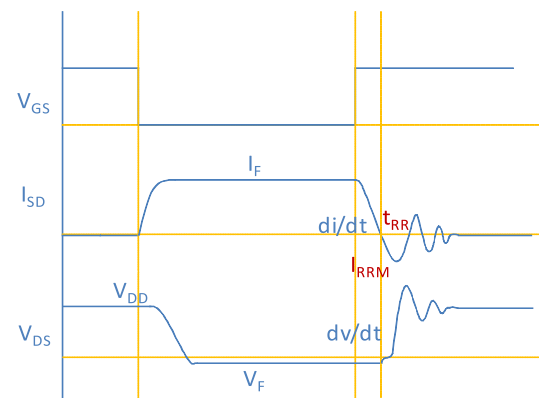

Package Outline

DFN3x3\_P, 8leads

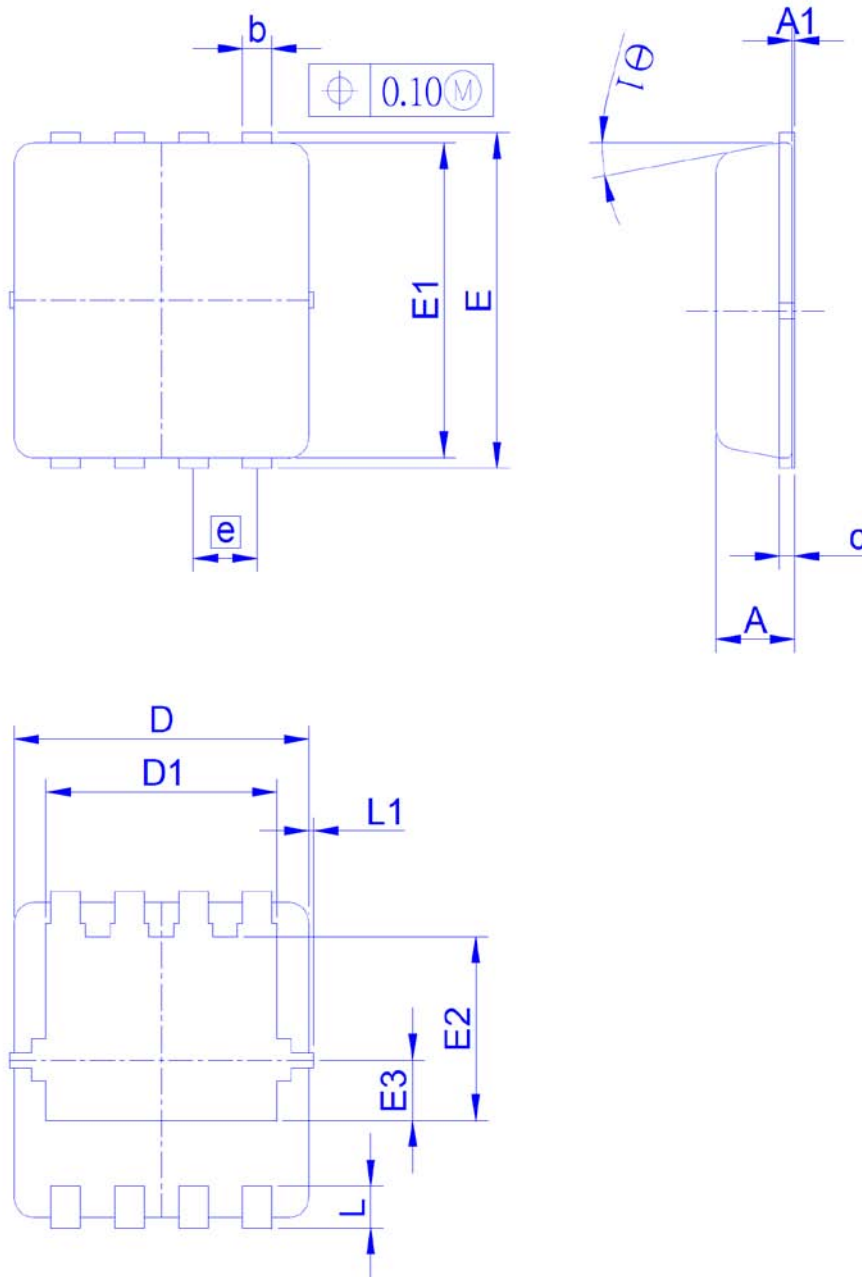

Dimension in mm

Dimension	A	A1	b	c	D	D1	E	E1	E2	E3	e	L	L1	$\theta$
Min.	0.70	0	0.24	0.10	2.95	2.25	3.15	2.95	1.65			0.30		0°
Typ.	0.80		0.30	0.152	3.00	2.35	3.20	3.00	1.75	0.575	0.65	0.40	0.13	10°
Max.	0.90	0.05	0.37	0.25	3.15	2.45	3.40	3.15	1.96			0.50		12°